

# ADMIRAL A2600H

## TECHNICAL DATA

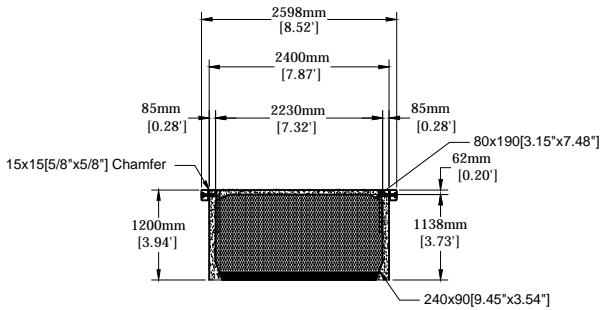

ADMIRAL A2600H  
SECTION A-A

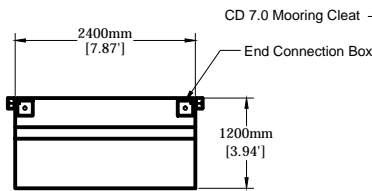

END ELEVATION VIEW

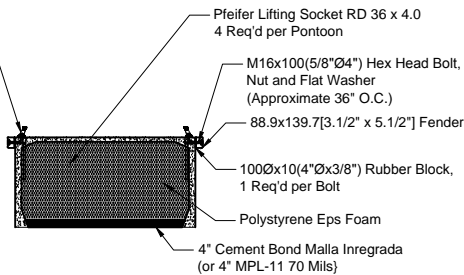

SECTION A-A  
SCALE 3/8" = 1'

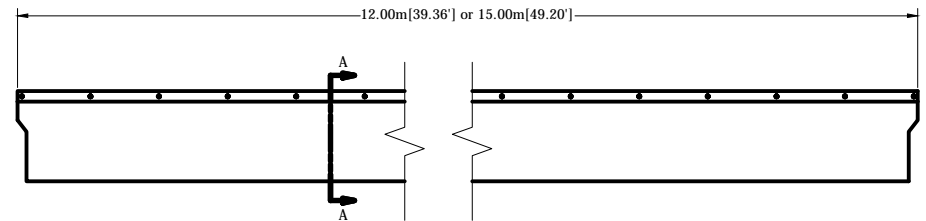
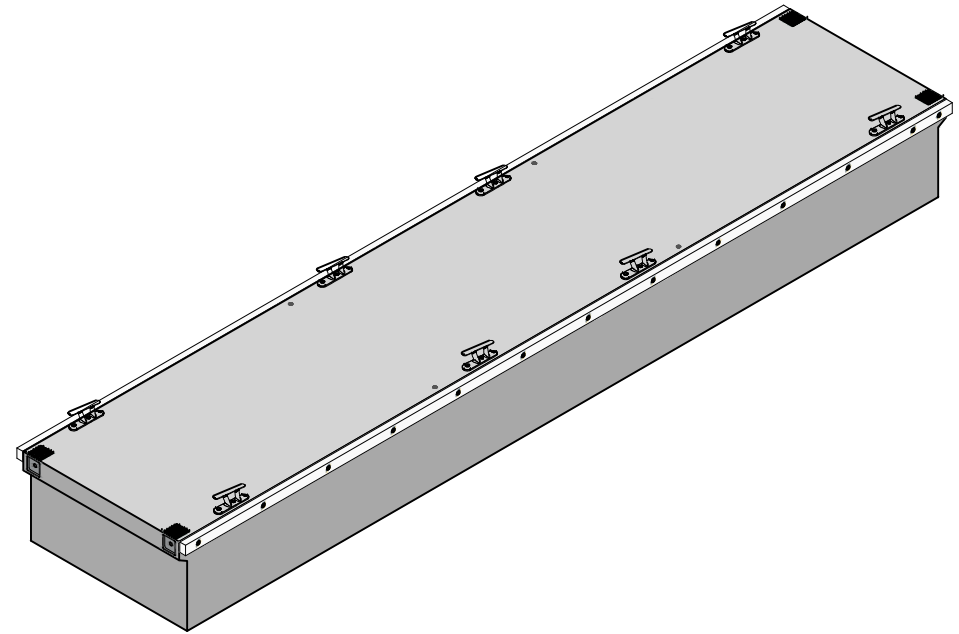

SIDE ELEVATION VIEW

ADMIRAL A2600H [8' width] Technical Data

Model	Total Width (meter/feet)	Concrete Width (meter/feet)	Height (meter/feet)	Length (meter/feet)	Freeboard (mm/inch)	Area (square meter/squarefeet)	Volume (cubic meter/cubic yard)	Weighth (kg/lbs)	Type
A2612H[8'x40']	2.60/8.52	2.40/7.87	1.20/3.94	12.00/39.36	650-700/25.58-27.55	32.40/348.75	33.80/44.21	14000-15500/30865-34172	Concrete
A2615H[8'x50']	2.60/8.52	2.40/7.87	1.20/3.94	15.00/49.20	650-700/25.58-27.55	36.00/387.50	42.44/55.51	17600-19800/38801-43652	Concrete