

ADMIRAL A1300H TECHNICAL DATA

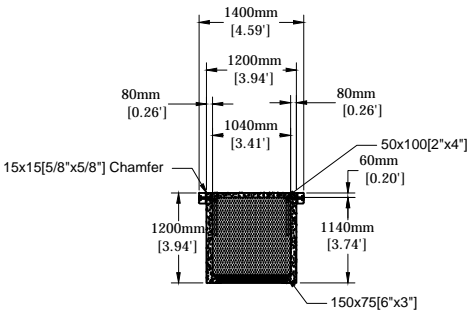

ADMIRAL A1300
SECTION A-A

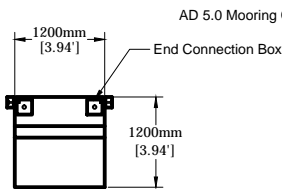

END ELEVATION VIEW

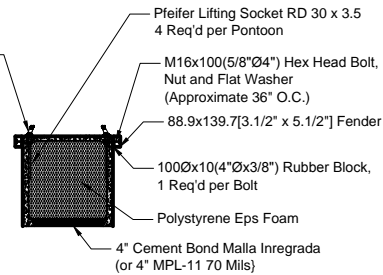

SECTION A-A
SCALE 3/8" = 1'

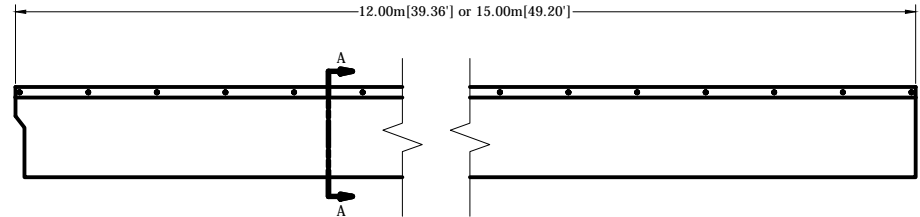
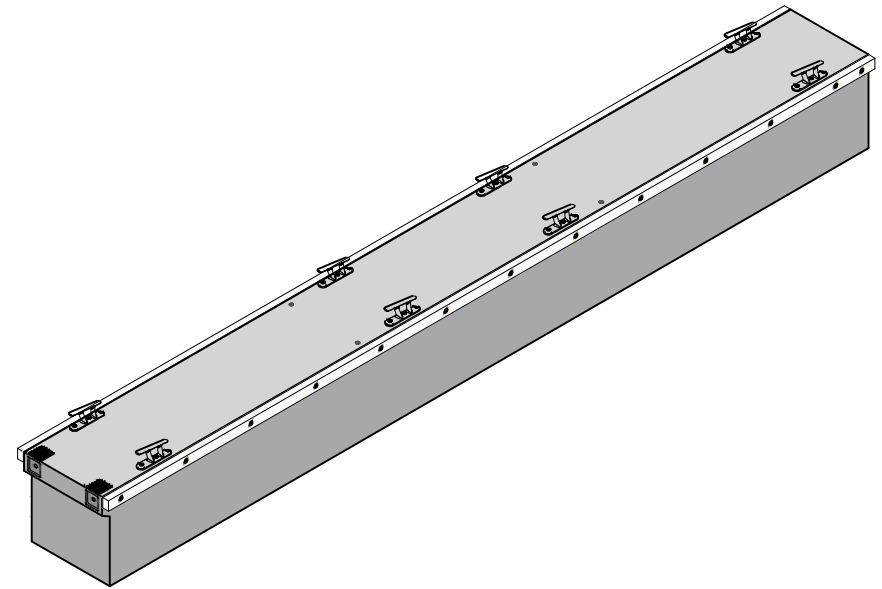

SIDE ELEVATION VIEW

ADMIRAL A1300H [4' width] Technical Data

Model	Total Width (meter/feet)	Concrete Width (meter/feet)	Height (meter/feet)	Length (meter/feet)	Freeboard (mm/inch)	Area (square meter/squarefeet)	Volume (cubic meter/cubic yard)	Weight (kg/lbs)	Type
A1312H[4'x40']	1.40/4.58	1.20/3.94	1.20/3.94	12.00/39.36	650-700/25.58-27.55	14.40/155.00	16.86/22.05	10138.00/22350.00	Concrete
A1315H[4'x50']	1.40/4.58	1.20/3.94	1.20/3.94	15.00/49.20	650-700/25.58-27.55	18.00/193.75	21.18/27.70	11753.00/25910.00	Concrete